

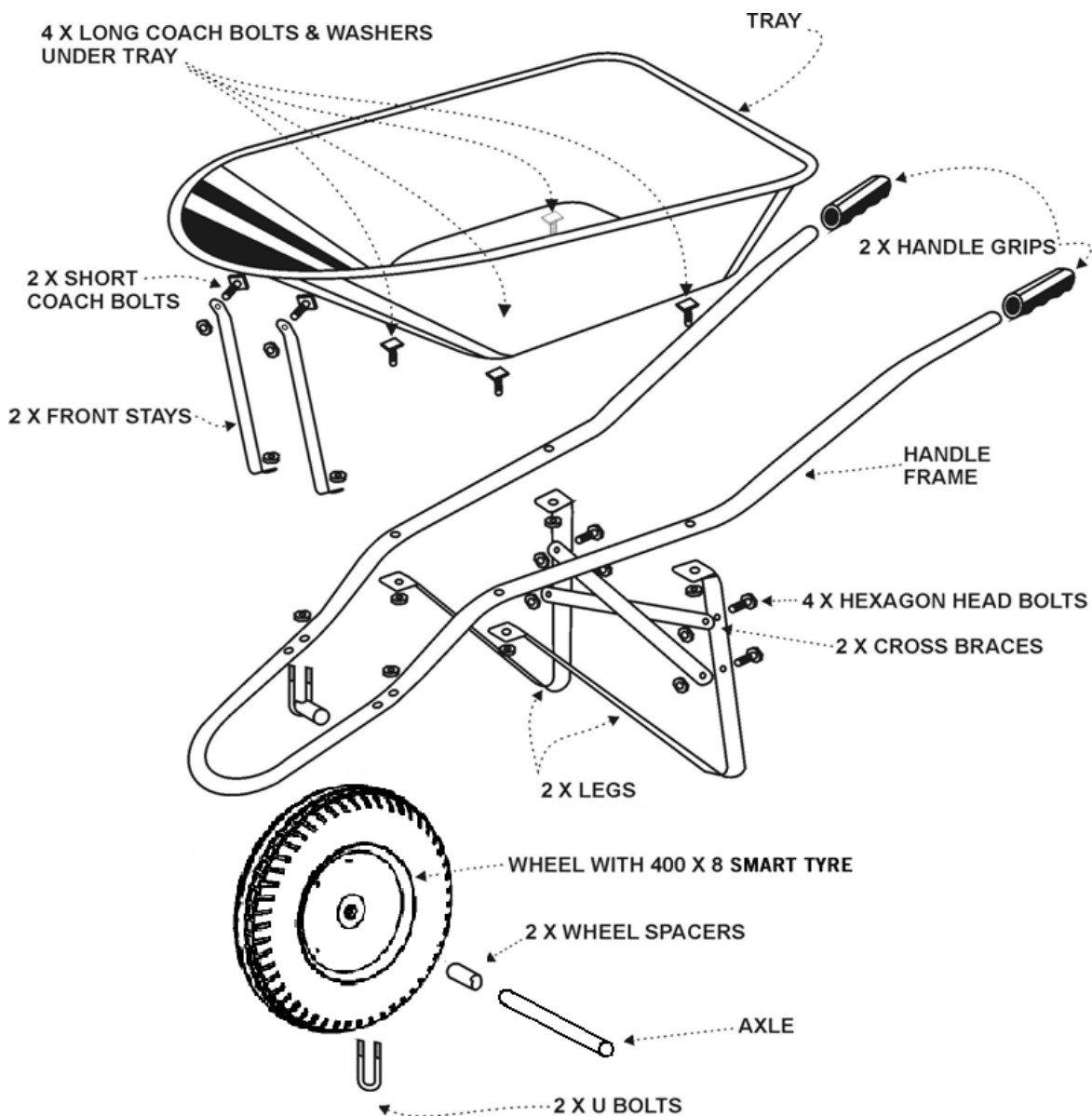

## CONTRACTOR EXTREME WHEELBARROW ASSEMBLY INSTRUCTIONS (BOLT-FREE TRAY)



# ASSEMBLY INSTRUCTIONS

**Important:** Only **finger tighten nuts** during assembly.

1. Place tray upside down on a bench.
2. Slide handgrips over the ends of the handle frame by inching on at first and then standing it on its end, pushing against the floor.
3. The handle frame needs to be spread apart at the open end so that the handle frame will fit over the rails welded to the underside of the tray. Spread the handle frame apart by laying one side on the ground and standing on it at the open end, then lifting directly up, until it is at the right angle. The bolt holes in the handle frame should match the slot-holes in the rails.
4. Take the four long coach bolts and slide a square washer over the shaft of each (no washer with Poly Contractors) and position the bolt head and washer in each of the slot-holes in the rail. After positioning the holes in handle frame over the bolts, lay the handle frame on the tray with the nose guard pointing upwards.
5. Position the legs over the same bolts, as shown and fit nuts.
6. To attach the front stays, slide a square washer over the two short coach bolts and fit into the slots at the front of the tray. Position the two front stays, with the right angle bend to the top and facing to the rear, over the bolts and fit nuts.
7. To fit the wheel, slide the axle through the wheel bearing and slide an axle spacer, with notch facing away from the wheel, onto either side. Hold the wheel inside the nose guard of the handle frame with the axle positioned so that the "U" bolts can be fitted into handle frame. Position the front stays over the front most leg of the "U" bolt; rotate axle spacer so that the notch sits against the handle frame and fit nut. Fit nut to the other leg of "U" bolt.
8. Attach the cross braces to the rear of the legs with the hexagon head bolts and nuts, **spreading the legs wide apart to position the cross braces.**
9. At this point the Wheelbarrow should be completely assembled and only requires the nuts to be tightened. Start by positioning the wheel in the centre, and tighten the "U" bolt nuts. Work from the front of the Wheelbarrow to the rear.

*YOU HAVE NOW COMPLETED THE ASSEMBLY OF YOUR GREENS CONTRACTOR EXTREME BARROW.  
WE TRUST THIS PROVIDES YOU WITH YEARS OF PRACTICAL USE.  
MANY THANKS*



Legs	
Front Stays	
Cross Stays	
Hardware Pack	
Axle	
Wheel	

Packed By .....

Date.....