

# ECO ASSEMBLY INSTRUCTIONS

- 1: M6 x 45mm Gutter Bolt
- 2: M6 x 20mm Gutter Bolt
- 3: M6 Hex Nut
- 4: M6 U-bolt
- 5: Axle Spacer
- 6: Axle Washer M17 x 30

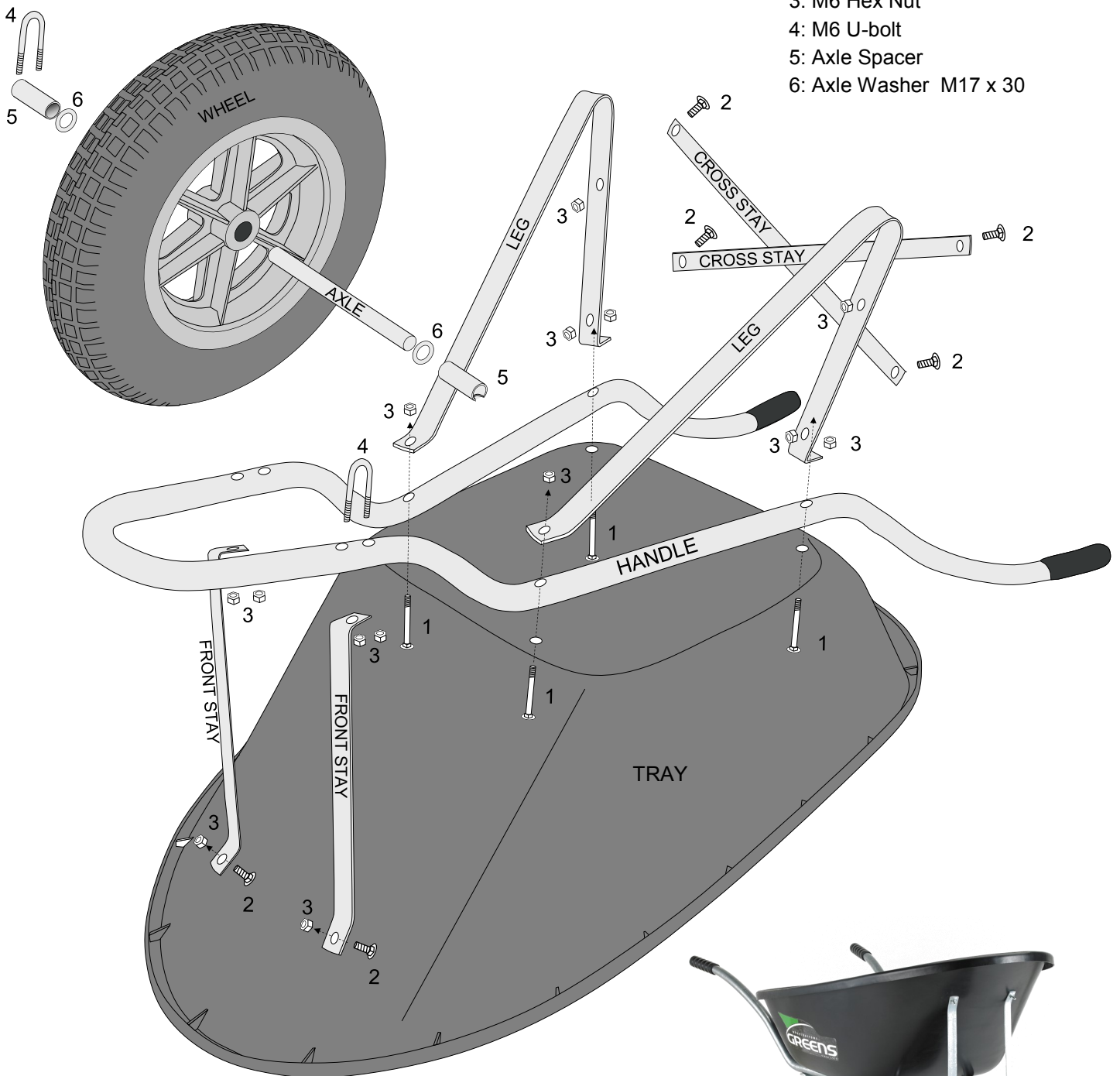

# ECO ASSEMBLY INSTRUCTIONS

**Important:** Only **finger tighten nuts** during assembly. All bolts to have flat washer, then a spring washer fitted before fitting nut.

1. Place tray upside down on a bench .
2. Lay handle on tray and push four long gutter bolts from inside tray through tray and handle frame.
3. Position legs on long bolts and finger tighten nuts.
4. Attach the cross braces to the rear of the legs with the hexagon head bolts and nuts, **spreading the legs wide apart to position the cross braces.**
5. To fit wheel, slide axle through wheel centre and slide axle washer and axle spacer over axle on both sides of wheel (notch on axle spacer should face away from wheel centre). Position wheel inside nose guard of the handle and locate it by placing U-bolts over axle into holes in handle.
6. Rotate axle spacers so that notch rests against handle frame.
7. Fit nuts to rear part of U-bolt.
8. Attach front stays to front of U-bolt and finger tighten nuts
9. Fasten front stays to tray with short gutter bolts from the inside of tray.
10. Tighten all nuts. Start with U-bolts first.

**YOU HAVE NOW COMPLETED THE ASSEMBLY OF YOUR GREENS ECO BARROW. WE TRUST THIS PROVIDES YOU WITH YEARS OF PRACTICAL USE.  
MANY THANKS**

## 2 YEAR WARRANTY- DOMESTIC USE

Your Greens ECO wheelbarrow is guaranteed for 2 years against faulty workmanship and materials only when used for domestic purposes. The cartage of heavy building materials will render the warranty void. Warranty excludes normal wear and tear and abuse. Manufacturers liability does not cover any colour change or fading to the tray, handgrips, wheel or tyre that may occur.

Any claims should be made in writing to the address below along with valid proof of purchase receipt. Liability is limited to the replacement of parts only.



*Riverlea Group Ltd*  
P.O. Box 11062, Hamilton 3251, New Zealand  
Ph +64 (7) 847 0204, Fx +64 (7) 847 0205  
E-mail [sales@riverleagroup.co.nz](mailto:sales@riverleagroup.co.nz)

Legs	
Front Stays	
Cross Stays	
Hardware Pack	
Axle	
Wheel	

Packed by:

Date: